

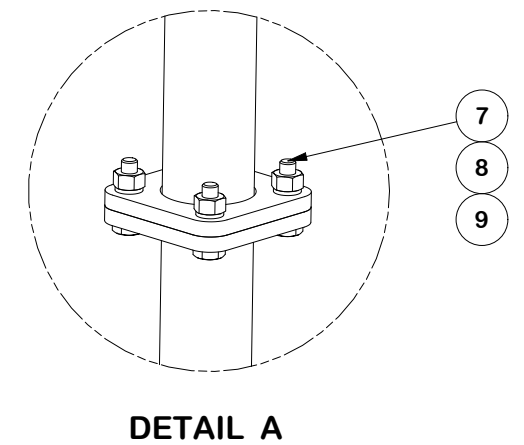

| PARTS LIST | | | | | | | | |
|-------------|-----|---------------|-------------|--|--------|----------|---------|--|
| ITEM | QTY | PART NO. | BOX NO. | PART DESCRIPTION | LENGTH | UNIT WT. | NET WT. | |
| 1 | 3 | X-232696 | | BALLAST TRAY WELDMENT - SITE PRO 1 | | 66.60 | 199.79 | |
| 2 | 5 | X-CSRT-P3096 | | 2-7/8" DIA. PIPE X 96" LONG | 96 in | 48.99 | 244.97 | |
| 3 | 3 | X-CSRT-3072FW | | CSRT FLANGE PIPE WELDMENT 2-7/8" X 72" | | 39.16 | 117.47 | |
| 4 | 3 | X-CSRT-3048FW | | CSRT FLANGE PIPE WELDMENT 2-7/8" X 48" | | 26.85 | 80.54 | |
| 5 | 12 | CSRT-PCB | P-CSRT-PCB | CSRT PIPE CLAMP BRACKET KIT | | 4.25 | 50.95 | |
| 6 | 10 | CSRT-GP30 | P-CSRT-GP30 | CSRT GUSSET PLATE KIT | | 10.49 | 104.85 | |
| 7 | 12 | G1202 | | 1/2" x 2" HDG HEX BOLT GR5 | 2 in | 0.18 | 2.11 | |
| 8 | 12 | G12LW | | 1/2" HDG LOCKWASHER | 1/8 in | 0.01 | 0.17 | |
| 9 | 12 | G12NUT | | 1/2" HDG HEAVY 2H HEX NUT | 7/8 in | 0.07 | 0.86 | |
| TOTAL WT. # | | | | | | | 801.70 | |



FINISH:
HOT DIP GALVANIZED.

| | | | | | | | | | | | | | | | |
|--|--|--|--|--|--|--|--|---|--|----------------------------------|---|-------------------------------------|--|-------------------------------|--|
| | | | | | TOLERANCE NOTES TOLERANCES ON DIMENSIONS, UNLESS OTHERWISE NOTED ARE: SAWED, SHEARED AND GAS CUT EDGES ($\pm 0.030"$) DRILLED AND GAS CUT HOLES ($\pm 0.030"$) - NO CONING OF HOLES LASER CUT EDGES AND HOLES ($\pm 0.010"$) - NO CONING OF HOLES BENDS AND ANGLES ARE $\pm 1/2$ DEGREE ALL OTHER MACHINING ($\pm 0.030"$) ALL OTHER ASSEMBLY ($\pm 0.060"$) | | | DESCRIPTION CSRT SERIES™ 2 PIPE SLOPE MOUNT 8' FACE X 10' MAST X 8' DEPTH | | |  Engineering Support Team: sp1engineering@valmont.com A valmont COMPANY | | | | |
| REVISION HISTORY | | | | | PATENT INFORMATION: WWW.SITEPRO1.COM/PATENTS | | | CPD NO. SP1 | | DRAWN BY SDR 10/8/2025 | | ENG. APPROVAL 11/11/2025 | | PART NO. CSRT2-8108 | |
| REV DESCRIPTION OF REVISIONS CPD BY DATE | | | | | PROPRIETARY NOTE: THE DATA AND TECHNIQUES CONTAINED IN THIS DRAWING ARE PROPRIETARY INFORMATION OF VALMONT INDUSTRIES AND CONSIDERED A TRADE SECRET. ANY USE OR DISCLOSURE WITHOUT THE CONSENT OF VALMONT INDUSTRIES IS STRICTLY PROHIBITED. | | | CLASS SUB 87 02 | | DRAWING USAGE CUSTOMER | | CHECKED BY ADB 11/11/2025 | | DWG. NO. CSRT2-8108 | |

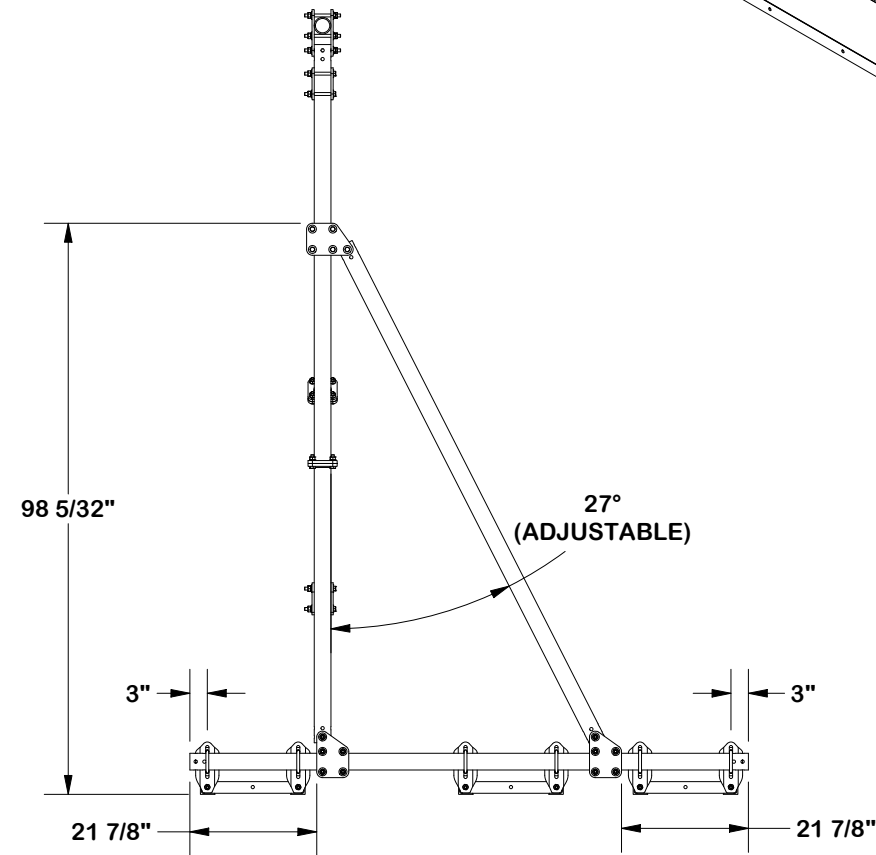
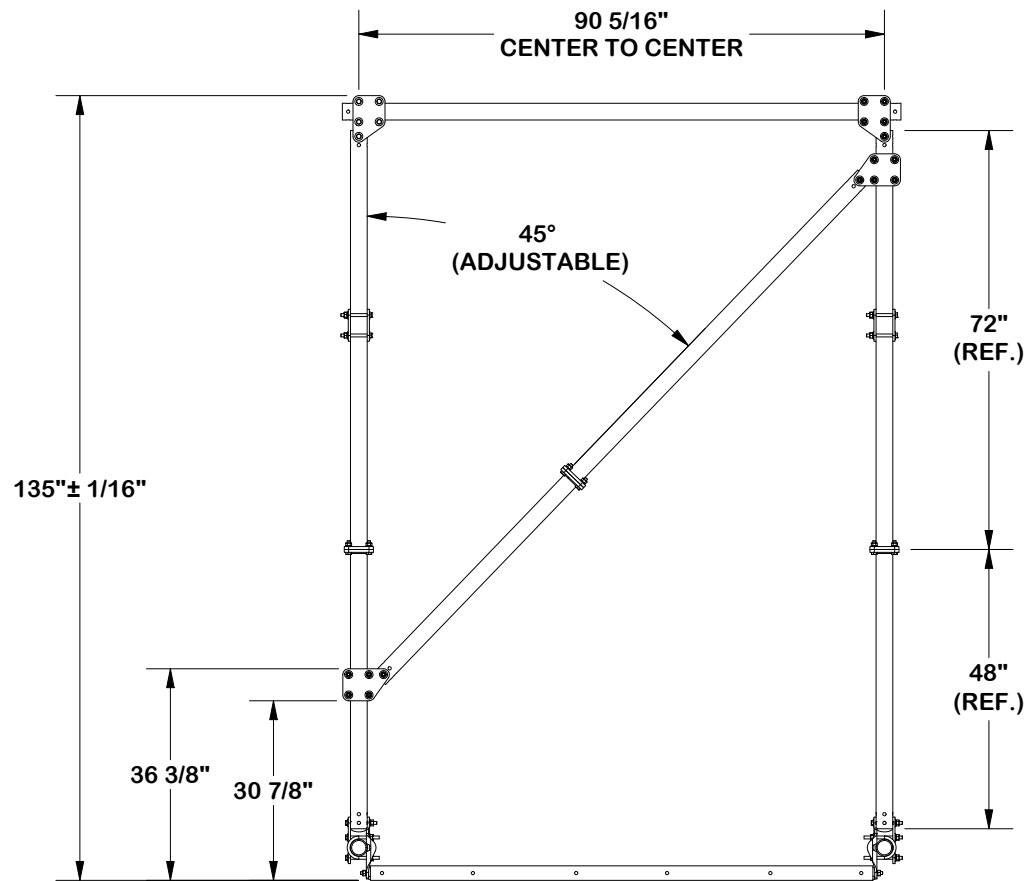
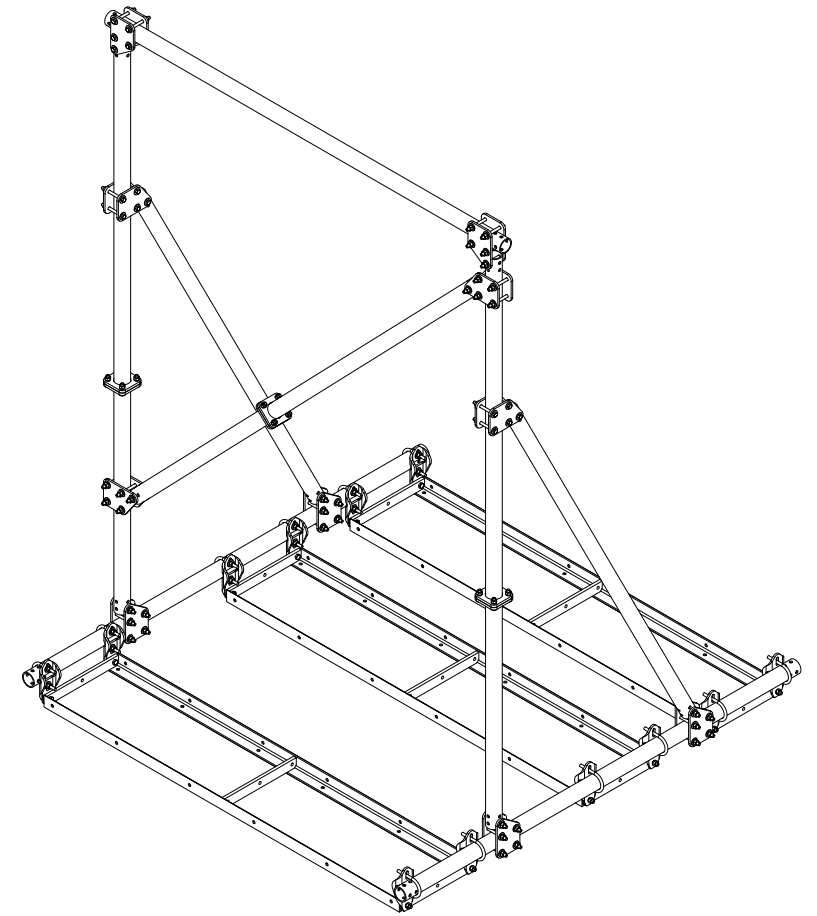
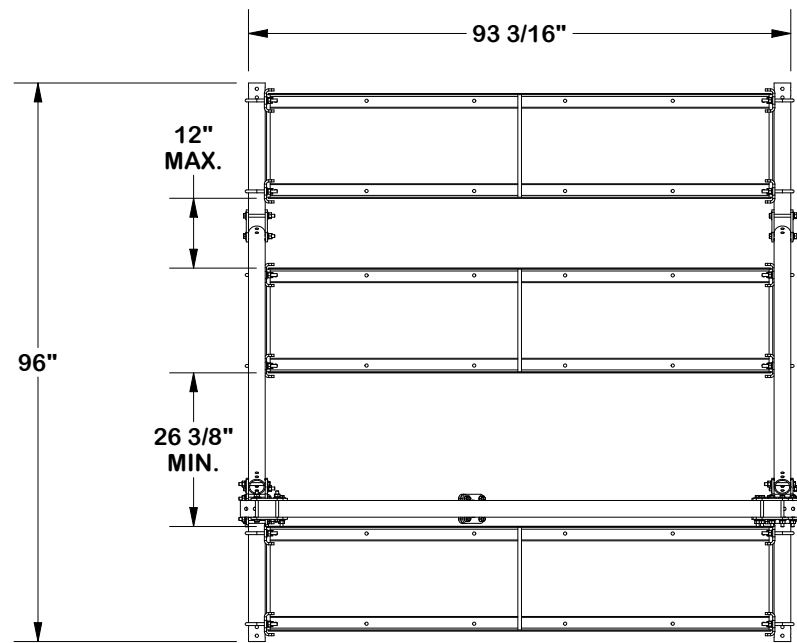

TOLERANCE NOTES

TOLERANCES ON DIMENSIONS, UNLESS OTHERWISE NOTED ARE:
 SAWED, SHEARED AND GAS CUT EDGES (± 0.030 ")
 DRILLED AND GAS CUT HOLES (± 0.030 ") - NO CONING OF HOLES
 LASER CUT EDGES AND HOLES (± 0.010 ") - NO CONING OF HOLES
 BENDS AND ANGLES ARE $\pm 1/2$ DEGREE
 ALL OTHER MACHINING (± 0.030 ")
 ALL OTHER ASSEMBLY (± 0.060 ")

PATENT INFORMATION: WWW.SITEPRO1.COM/PATENTS

PROPRIETARY NOTE:
 THE DATA AND TECHNIQUES CONTAINED IN THIS DRAWING ARE PROPRIETARY INFORMATION OF VALMONT INDUSTRIES AND CONSIDERED A TRADE SECRET. ANY USE OR DISCLOSURE WITHOUT THE CONSENT OF VALMONT INDUSTRIES IS STRICTLY PROHIBITED.

DESCRIPTION
CSRT SERIES™ 2 PIPE SLOPE MOUNT
8' FACE X 10' MAST X 8' DEPTH

SITE PRO 1
 A valmont COMPANY
 Engineering Support Team:
 sp1engineering@valmont.com

| | | |
|-------------------------------------|----------------------------------|------------------------------------|
| CPD NO. SP1 | DRAWN BY SDR 10/8/2025 | ENG. APPROVAL 11/11/2025 |
| CLASS 87 | SUB 02 | DRAWING USAGE CUSTOMER |
| CHECKED BY ADB 11/11/2025 | | |

| |
|-------------------------------|
| PART NO. CSRT2-8108 |
| DWG. NO. CSRT2-8108 |

CSRT™ SLOPE REFERENCE

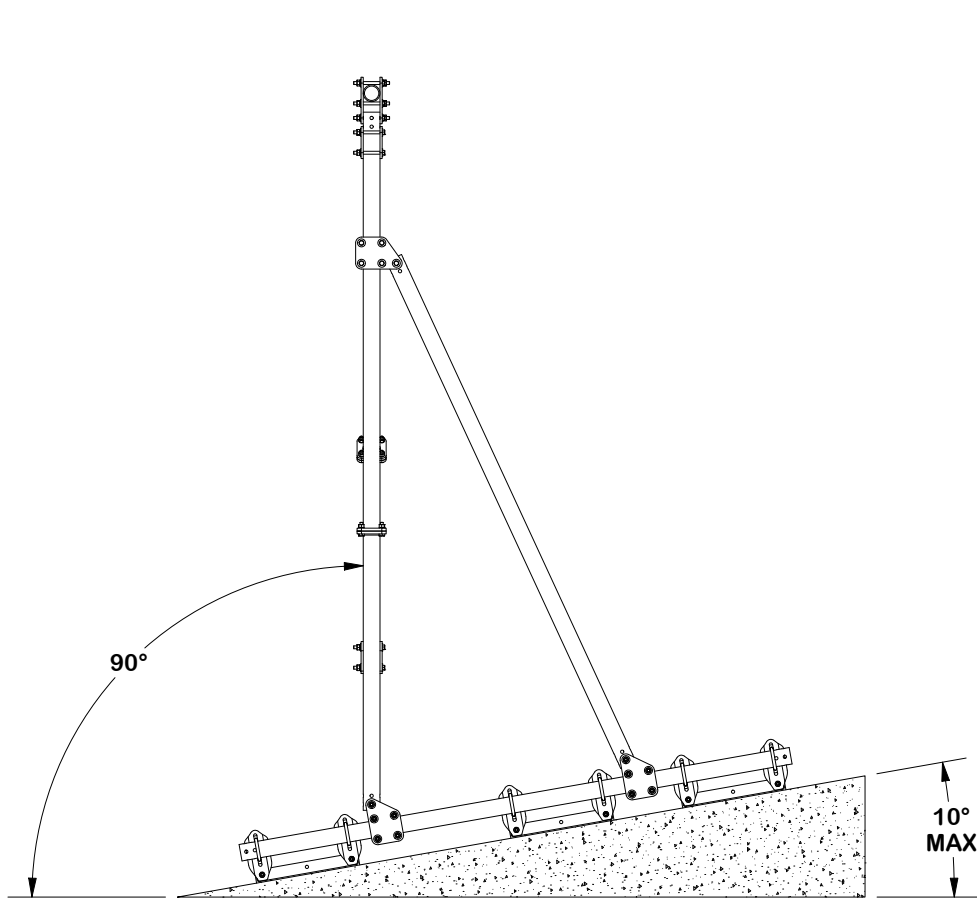

RIGHT SIDE VIEW
FRONT SLOPE

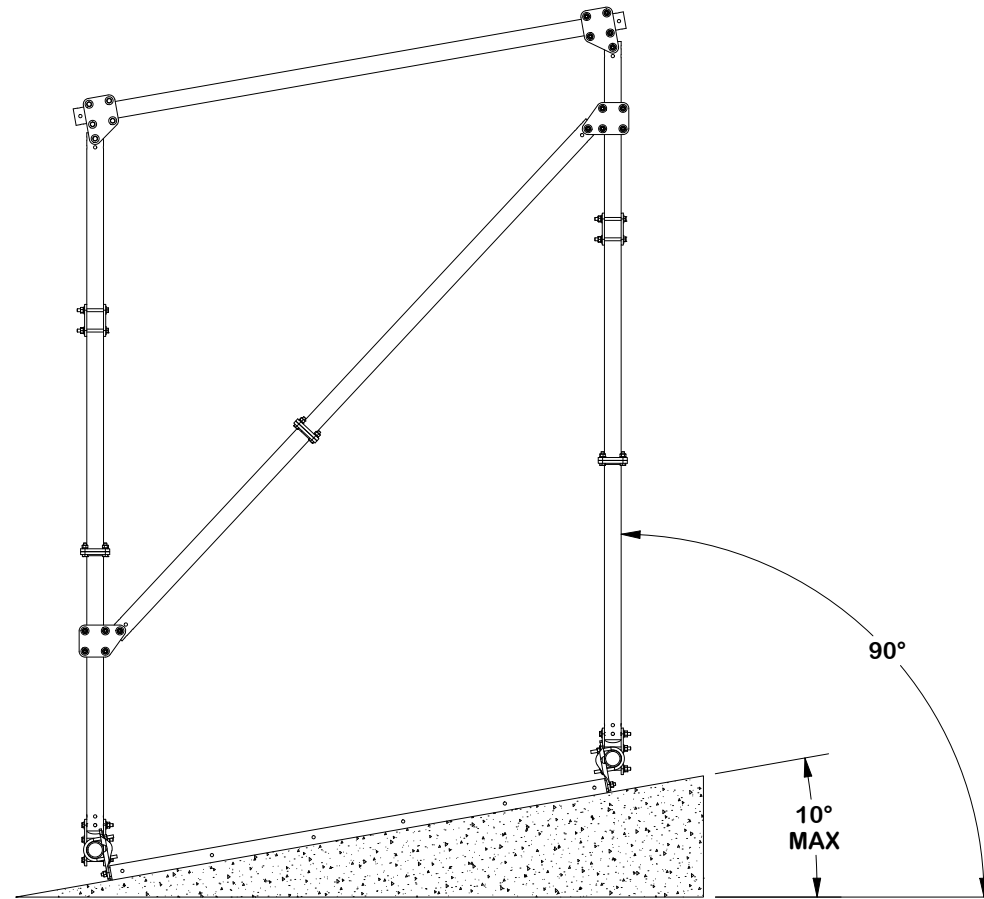

FRONT VIEW
SIDE SLOPE

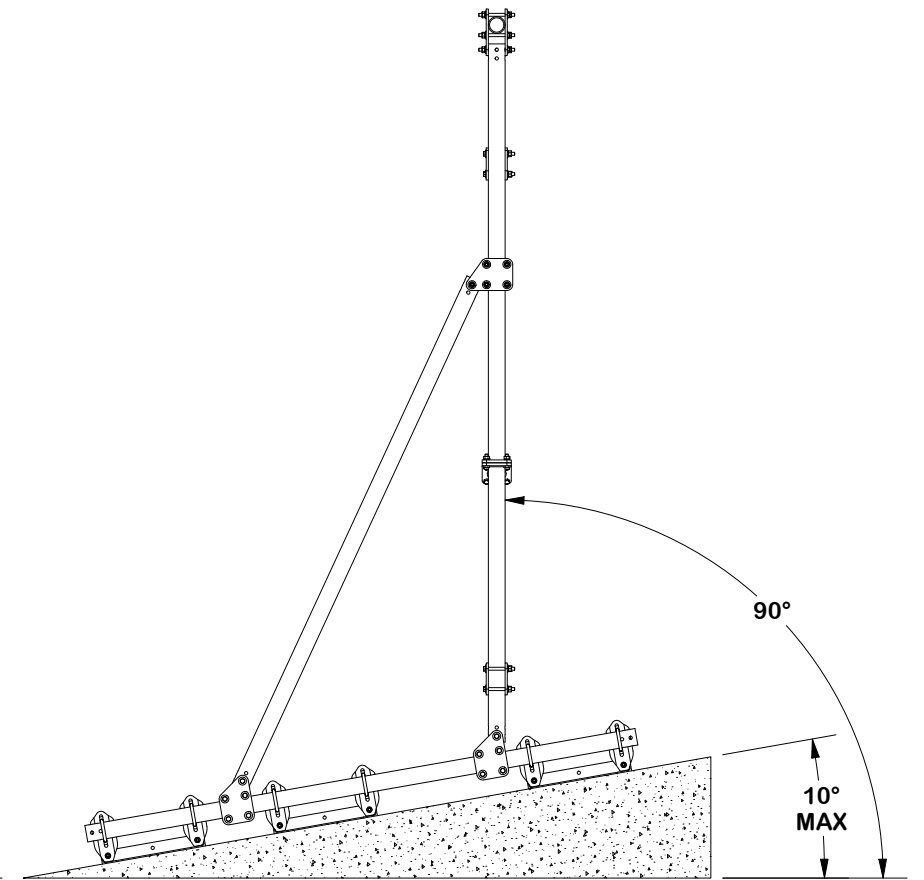

LEFT SIDE VIEW
BACK SLOPE

TOLERANCE NOTES

TOLERANCES ON DIMENSIONS, UNLESS OTHERWISE NOTED ARE:
 SAWED, SHEARED AND GAS CUT EDGES ($\pm 0.030"$)
 DRILLED AND GAS CUT HOLES ($\pm 0.030"$) - NO CONING OF HOLES
 LASER CUT EDGES AND HOLES ($\pm 0.010"$) - NO CONING OF HOLES
 BENDS AND ANGLES ARE $\pm 1/2$ DEGREE
 ALL OTHER MACHINING ($\pm 0.030"$)
 ALL OTHER ASSEMBLY ($\pm 0.060"$)

PATENT INFORMATION: WWW.SITEPRO1.COM/PATENTS

PROPRIETARY NOTE:
 THE DATA AND TECHNIQUES CONTAINED IN THIS DRAWING ARE PROPRIETARY INFORMATION OF VALMONT INDUSTRIES AND CONSIDERED A TRADE SECRET. ANY USE OR DISCLOSURE WITHOUT THE CONSENT OF VALMONT INDUSTRIES IS STRICTLY PROHIBITED.

DESCRIPTION
CSRT SERIES™ 2 PIPE SLOPE MOUNT
8' FACE X 10' MAST X 8' DEPTH

| | | |
|-------------------------------------|----------------------------------|------------------------------------|
| CPD NO. SP1 | DRAWN BY SDR 10/8/2025 | ENG. APPROVAL 11/11/2025 |
| CLASS 87 | SUB 02 | DRAWING USAGE CUSTOMER |
| CHECKED BY ADB 11/11/2025 | | |

SITE PRO 1
 A valmont COMPANY
 Engineering Support Team:
 sp1engineering@valmont.com

| | |
|------------------------------------|-----------------------|
| PART NO. CSRT™ SLOPE REF | PAGE 3 OF 5 |
| DWG. NO. CSRT2-8108 | |

| PARTS LIST | | | | | | |
|------------|-----|------------|---------------------------------|---------|-------------|---------|
| ITEM | QTY | PART NO. | PART DESCRIPTION | LENGTH | UNIT WT. | NET WT. |
| 1 | 1 | X-CSRT-PCB | PIPE CONNECTION BRACKET | 12 in | 3.01 | 3.01 |
| 2 | 1 | X-UB1300 | 1/2" X 3" X 5" X 2" GALV U-BOLT | | 0.74 | 0.74 |
| 3 | 1 | G1202 | 1/2" x 2" HDG HEX BOLT GR5 | 2 in | 0.18 | 0.18 |
| 4 | 2 | G12FW | 1/2" HDG USS FLATWASHER | 3/32 in | 0.03 | 0.07 |
| 5 | 3 | G12LW | 1/2" HDG LOCKWASHER | 1/8 in | 0.01 | 0.04 |
| 6 | 3 | G12NUT | 1/2" HDG HEAVY 2H HEX NUT | 7/8 in | 0.07 | 0.21 |
| | | | | | TOTAL WT. # | 4.25 |

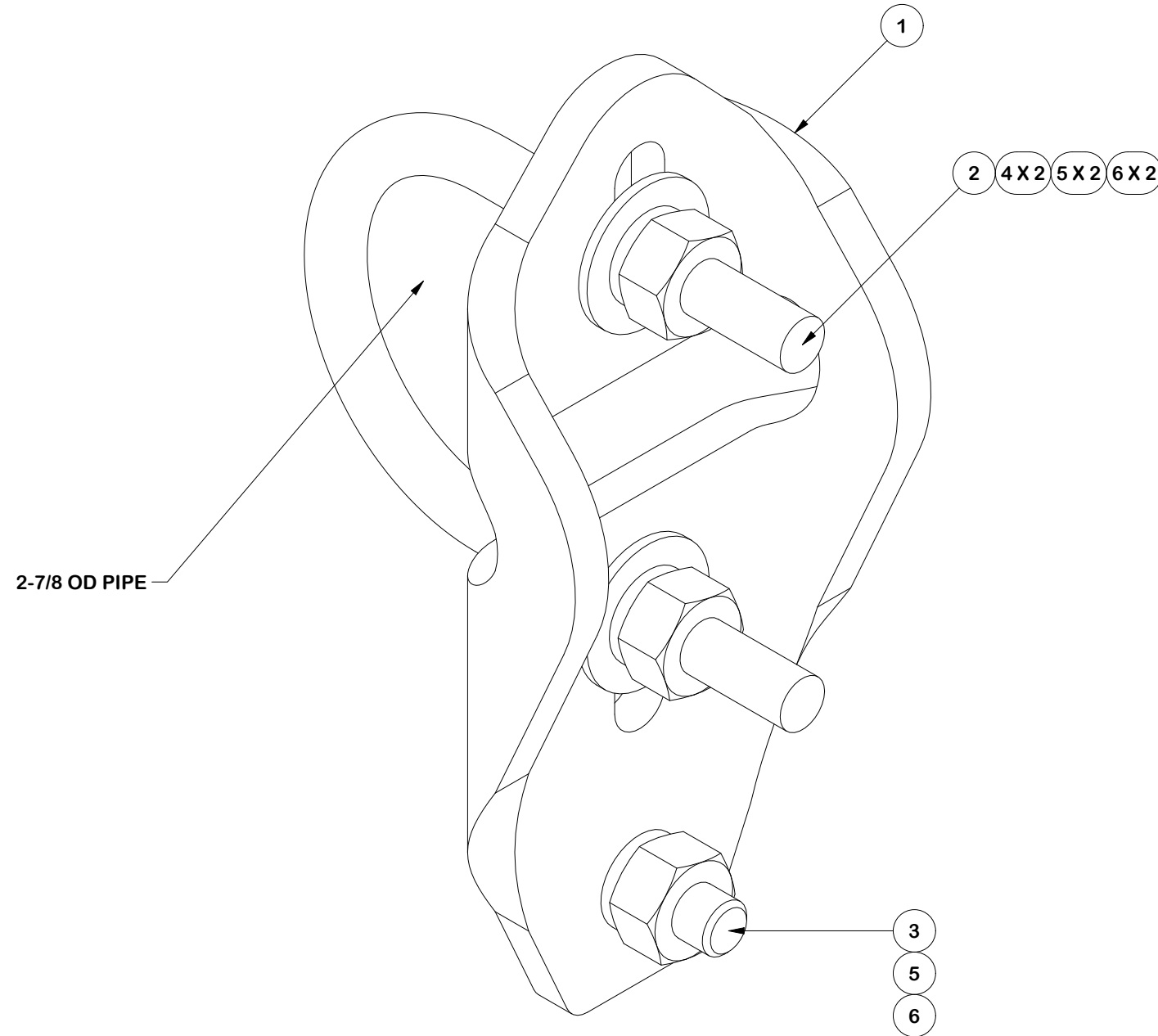

FINISH:
HOT DIP GALVANIZED.

TOLERANCE NOTES

TOLERANCES ON DIMENSIONS, UNLESS OTHERWISE NOTED ARE:
 SAWED, SHEARED AND GAS CUT EDGES ($\pm 0.030"$)
 DRILLED AND GAS CUT HOLES ($\pm 0.030"$) - NO CONING OF HOLES
 LASER CUT EDGES AND HOLES ($\pm 0.010"$) - NO CONING OF HOLES
 BENDS AND ANGLES ARE $\pm 1/2$ DEGREE
 ALL OTHER MACHINING ($\pm 0.030"$)
 ALL OTHER ASSEMBLY ($\pm 0.060"$)

PATENT INFORMATION: WWW.SITEPRO1.COM/PATENTS

PROPRIETARY NOTE:
 THE DATA AND TECHNIQUES CONTAINED IN THIS DRAWING ARE PROPRIETARY INFORMATION OF VALMONT INDUSTRIES AND CONSIDERED A TRADE SECRET. ANY USE OR DISCLOSURE WITHOUT THE CONSENT OF VALMONT INDUSTRIES IS STRICTLY PROHIBITED.

DESCRIPTION
**CSRT SERIES™ 2 PIPE SLOPE MOUNT
 8' FACE X 10' MAST X 8' DEPTH**

SITE PRO 1
 A valmont COMPANY
 Engineering Support Team:
 sp1engineering@valmont.com

| | | |
|-------------------------------------|----------------------------------|------------------------------------|
| CPD NO. SP1 | DRAWN BY SDR 10/8/2025 | ENG. APPROVAL 11/11/2025 |
| CLASS 87 | SUB 02 | DRAWING USAGE CUSTOMER |
| CHECKED BY ADB 11/11/2025 | | |

| | |
|-------------------------------|-----------------------|
| PART NO. CSRT-PCB | PAGE 4 OF 5 |
| DWG. NO. CSRT2-8108 | |

| PARTS LIST | | | | | | |
|------------|-----|-------------|--|---------|-------------|---------|
| ITEM | QTY | PART NO. | PART DESCRIPTION | LENGTH | UNIT WT. | NET WT. |
| 1 | 2 | X-CSRT-GP30 | 3" GUSSET PLATE | 12 in | 4.04 | 8.09 |
| 2 | 5 | G1205 | 1/2" x 5" HDG HEX BOLT GR5 FULL THREAD | 5 in | 0.33 | 1.63 |
| 3 | 10 | G12FW | 1/2" HDG USS FLATWASHER | 3/32 in | 0.03 | 0.34 |
| 4 | 5 | G12LW | 1/2" HDG LOCKWASHER | 1/8 in | 0.01 | 0.07 |
| 5 | 5 | G12NUT | 1/2" HDG HEAVY 2H HEX NUT | 7/8 in | 0.07 | 0.36 |
| | | | | | TOTAL WT. # | 10.49 |

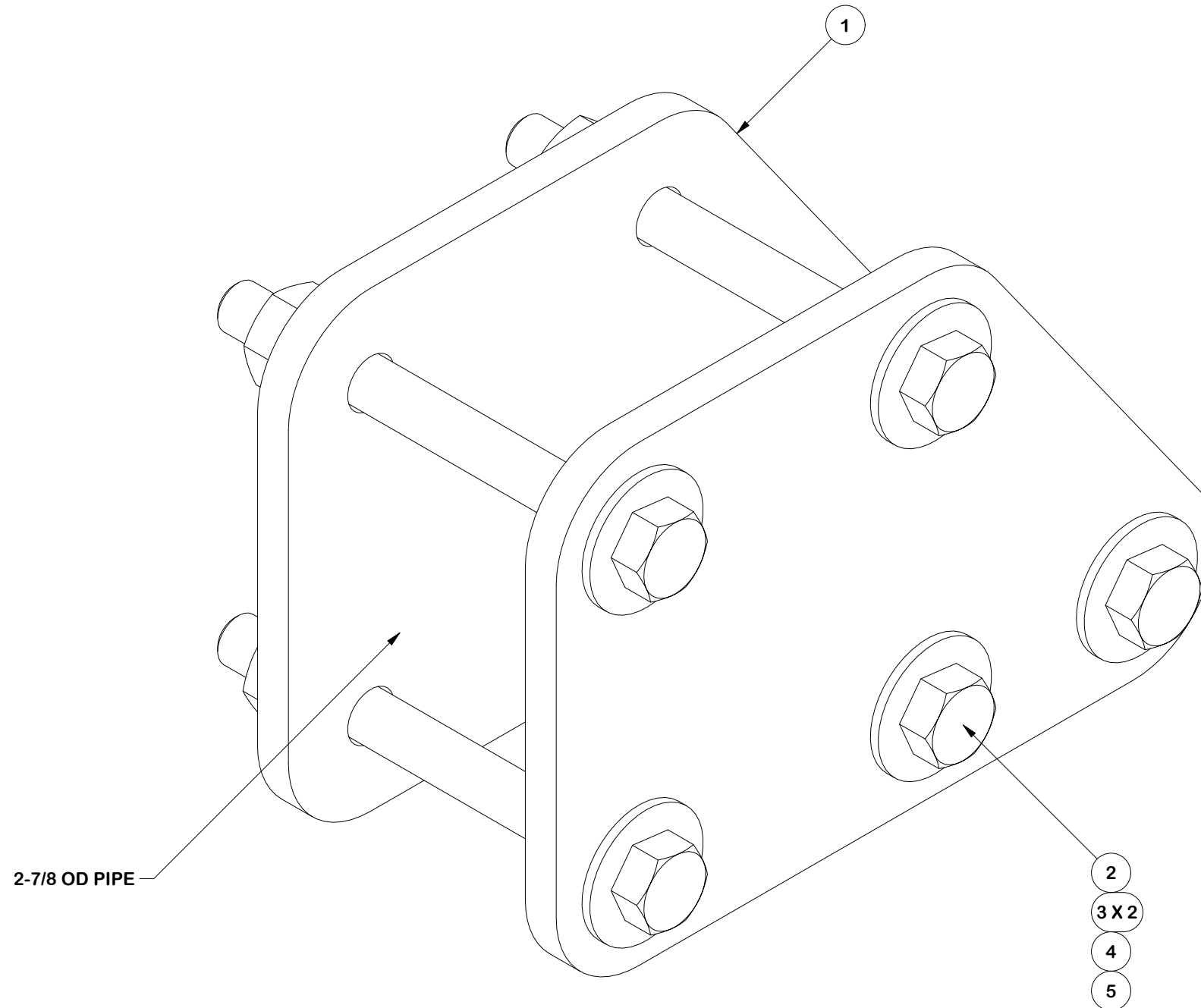

FINISH:
HOT DIP GALVANIZED.

TOLERANCE NOTES

TOLERANCES ON DIMENSIONS, UNLESS OTHERWISE NOTED ARE:
 SAWED, SHEARED AND GAS CUT EDGES ($\pm 0.030"$)
 DRILLED AND GAS CUT HOLES ($\pm 0.030"$) - NO CONING OF HOLES
 LASER CUT EDGES AND HOLES ($\pm 0.010"$) - NO CONING OF HOLES
 BENDS AND ANGLES ARE $\pm 1/2$ DEGREE
 ALL OTHER MACHINING ($\pm 0.030"$)
 ALL OTHER ASSEMBLY ($\pm 0.060"$)

PATENT INFORMATION: WWW.SITEPRO1.COM/PATENTS

PROPRIETARY NOTE:
 THE DATA AND TECHNIQUES CONTAINED IN THIS DRAWING ARE PROPRIETARY INFORMATION OF VALMONT INDUSTRIES AND CONSIDERED A TRADE SECRET. ANY USE OR DISCLOSURE WITHOUT THE CONSENT OF VALMONT INDUSTRIES IS STRICTLY PROHIBITED.

DESCRIPTION
**CSRT SERIES™ 2 PIPE SLOPE MOUNT
 8' FACE X 10' MAST X 8' DEPTH**

| | | |
|-------------------------------------|----------------------------------|------------------------------------|
| CPD NO. SP1 | DRAWN BY SDR 10/8/2025 | ENG. APPROVAL 11/11/2025 |
| CLASS 87 | SUB 02 | DRAWING USAGE CUSTOMER |
| CHECKED BY ADB 11/11/2025 | | |



Engineering Support Team:
 sp1engineering@valmont.com

| |
|-------------------------------|
| PART NO. CSRT-GP30 |
| DWG. NO. CSRT2-8108 |